

| | | | | | | | | |
|---|---|--|------|----------|-----|--|--|---|
| USED ON: | DRAWN BY: HUNTER TANKERSLEY | CONTINENTAL PUMP COMPANY 29425 STATE HIGHWAY B WARRENTON, MISSOURI 63383 PHONE: (636) 456-6006 FAX: (636) 456-4337 www.continentalultrapumps.com | | | | | | |
| MATERIAL: | DATE: 2/10/2025 | | | | | | | |
| UNLESS OTHERWISE SPECIFIED: DIMENSIONS ARE IN INCHES TOLERANCES: FRACTIONAL ± ANGULAR: MACH ± BEND ± TWO PLACE DECIMAL ± THREE PLACE DECIMAL ± | PROPRIETARY AND CONFIDENTIAL THE INFORMATION CONTAINED IN THIS DRAWING IS THE SOLE PROPERTY OF CONTINENTAL PUMP COMPANY. ANY REPRODUCTION IN PART OR AS A WHOLE WITHOUT THE WRITTEN PERMISSION OF CONTINENTAL PUMP COMPANY IS PROHIBITED. | TITLE: 3CL2 ASSEMBLY DRAWING | | | | | | |
| | | <table border="1"> <tr> <td>SIZE</td> <td>DWG. NO.</td> <td>REV</td> </tr> <tr> <td></td> <td></td> <td>-</td> </tr> </table> | SIZE | DWG. NO. | REV | | | - |
| SIZE | DWG. NO. | REV | | | | | | |
| | | - | | | | | | |
| | | DO NOT SCALE DRAWING SHEET 1 OF 2 | | | | | | |

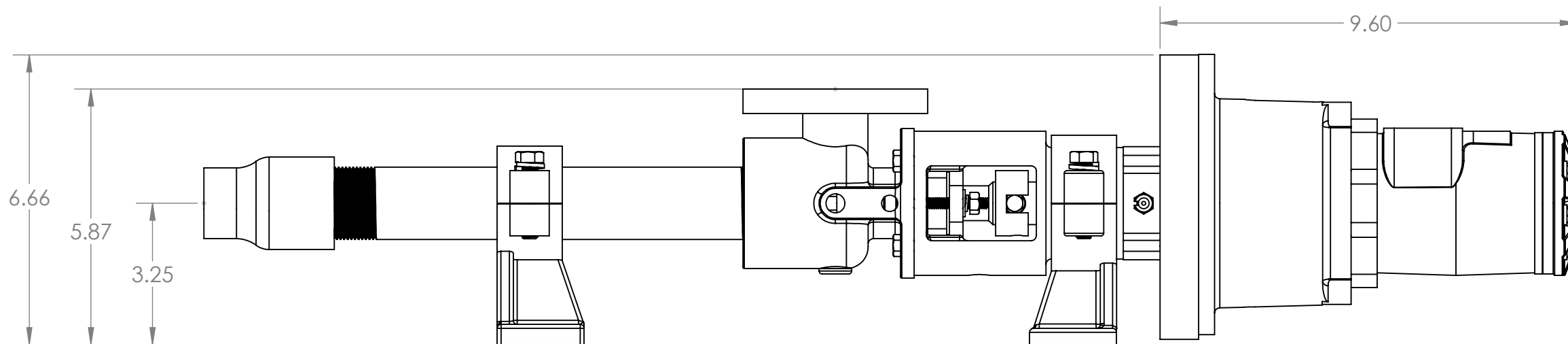
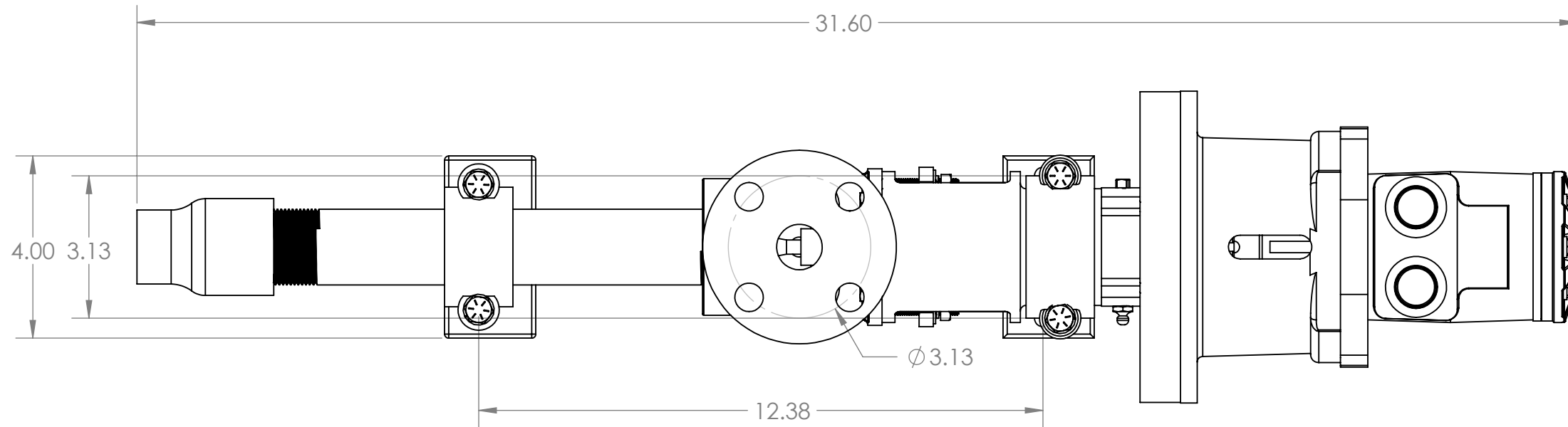

**SUCTION SIZE - 1" 150# FLANGE
DISCHARGE SIZE - 3/4" NPT**

| | | | |
|---|---|--|--------------|
| USED ON: | DRAWN BY: HUNTER TANKERSLEY | CONTINENTAL PUMP COMPANY 29425 STATE HIGHWAY B WARRENTON, MISSOURI 63383 PHONE: (636) 456-6006 FAX: (636) 456-4337 www.continentalultrapumps.com | |
| MATERIAL: | DATE: 2/10/2025 | TITLE: 3CL2 ASSEMBLY DRAWING | |
| UNLESS OTHERWISE SPECIFIED: DIMENSIONS ARE IN INCHES TOLERANCES: FRACTIONAL ± ANGULAR: MACH ± BEND ± TWO PLACE DECIMAL ± THREE PLACE DECIMAL ± | PROPRIETARY AND CONFIDENTIAL THE INFORMATION CONTAINED IN THIS DRAWING IS THE SOLE PROPERTY OF CONTINENTAL PUMP COMPANY. ANY REPRODUCTION IN PART OR AS A WHOLE WITHOUT THE WRITTEN PERMISSION OF CONTINENTAL PUMP COMPANY IS PROHIBITED. | SIZE | REV |
| | | DWG. NO. | - |
| | | DO NOT SCALE DRAWING | SHEET 2 OF 2 |