

CPML Pump End Kit Installation (CPML15-44K)

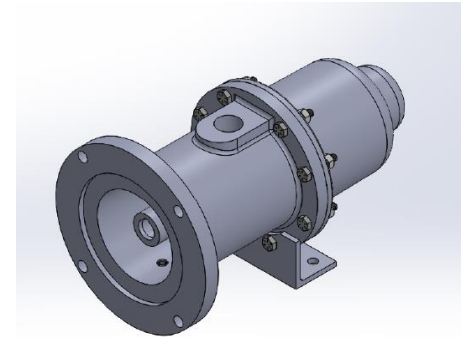
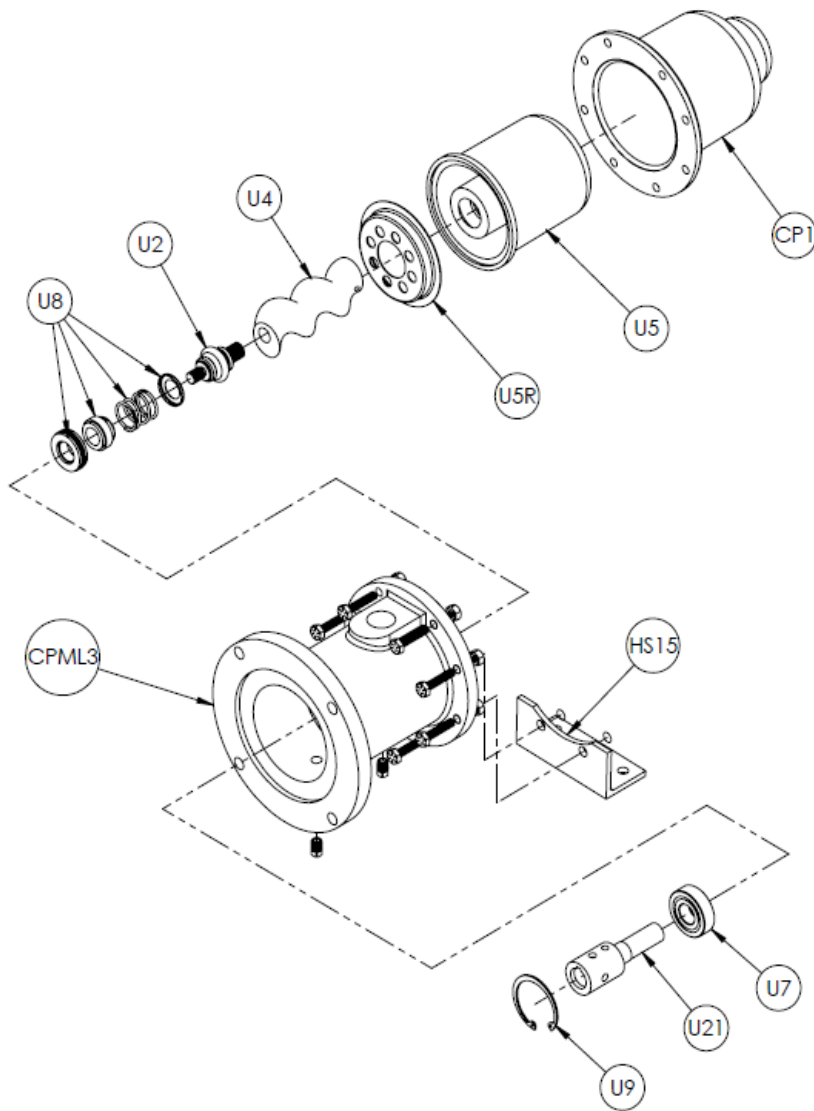

These kits are preassembled for a convenient **“Bolt and Go”** installation to any C Face Motor of your choice. Our unique feature makes this a fast and easy way to perform maintenance on our CPML Pump. Available with horizontal or vertical suction housings.

1. Stand the motor or the driver of the pump vertically with the shaft up.
2. Apply small amount of grease to the shaft and keyway.
3. Slide female motor coupling and pump assembly onto the male motor shaft or driver. Be sure to align the keyway in the female motor coupling, #U21.
4. Align the C-Face mounting holes with the discharge port being in the top or vertical position.
5. Tighten down the pump assembly with the 4 bolts and lock washers that are supplied in the kit.
NOTE: It may be necessary to loosen the 2 bottom feet bolts, #HS, to level both the pump and motor/driver, then retighten.
6. Follow rotation arrows on discharge housing to pump does not unthread on startup.